

T3 102

T4 136



pozi



6 pans



SQ

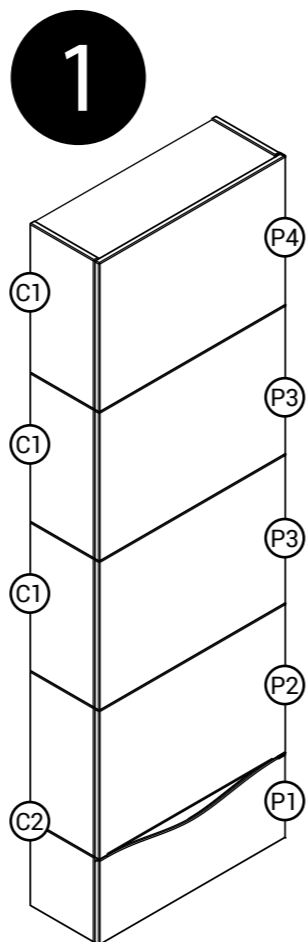

P1 x1

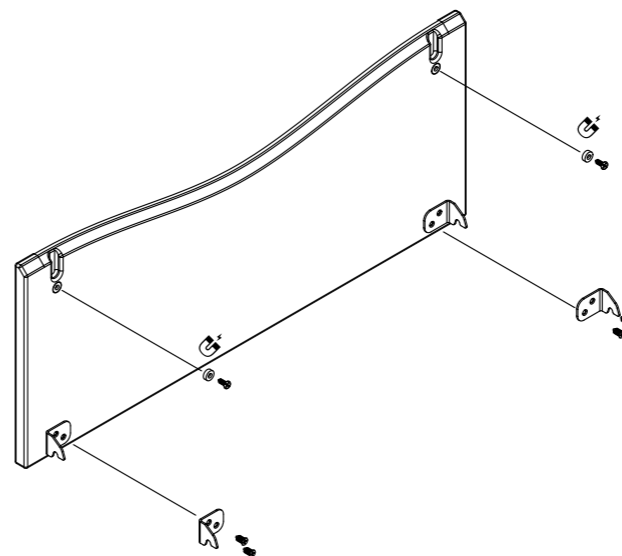

P2 x1

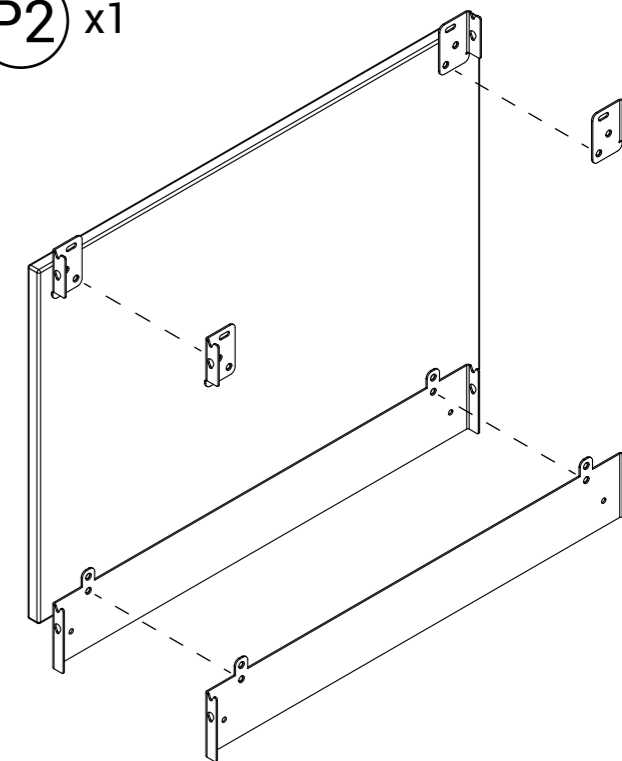

VISSER LES FERRURES SUR
LES FAÇADES ET LES CÔTÉS

Version 161025

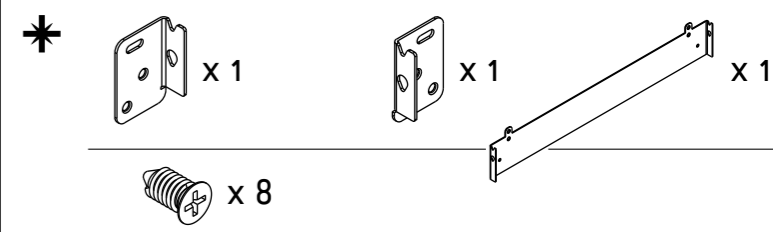
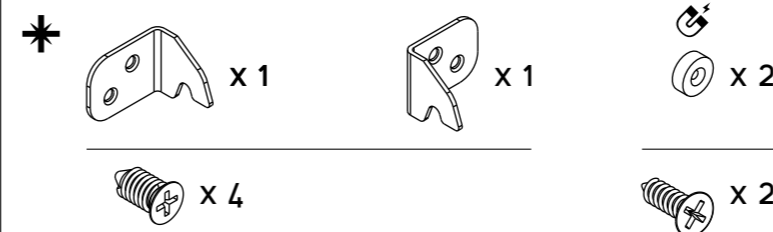

C1 x6

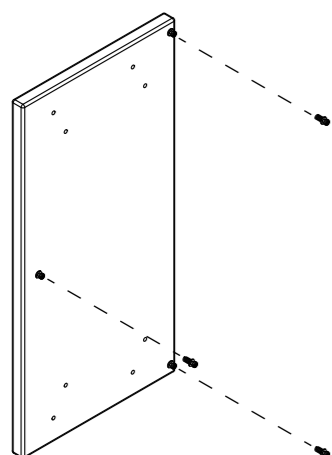

C2 x(1 + symétrique)

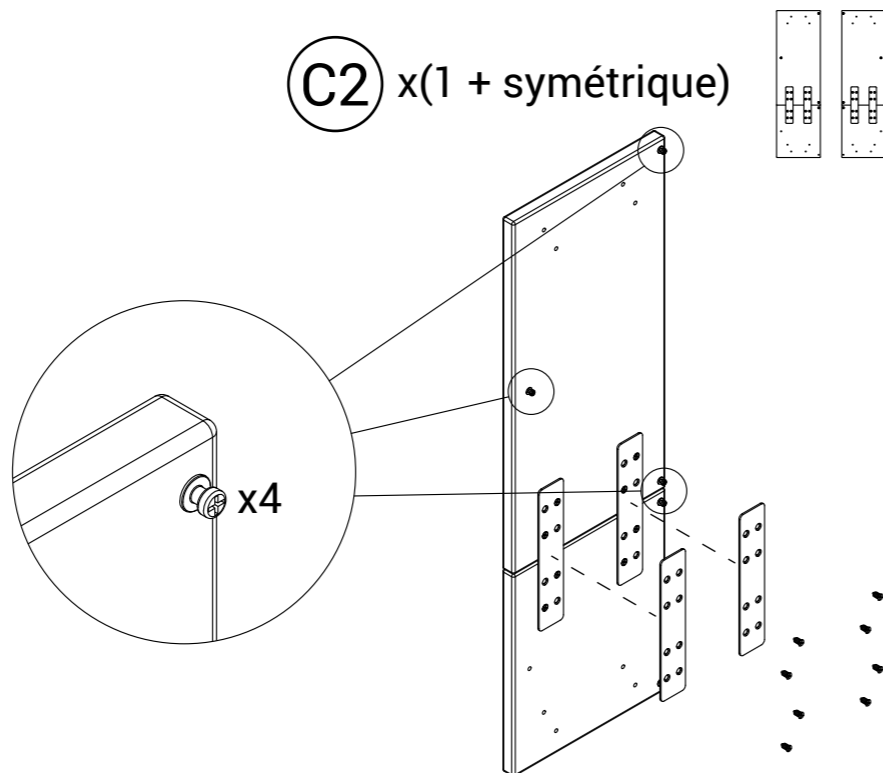

P3 x2

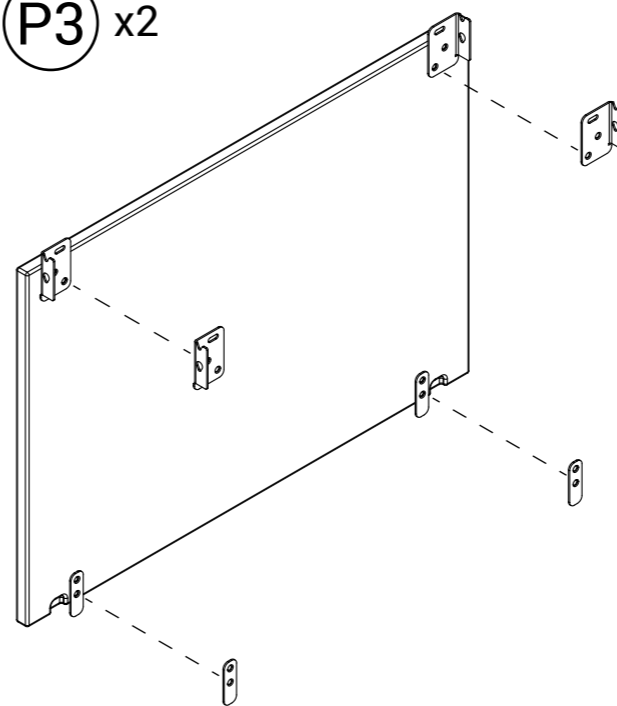

P4 x1

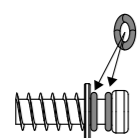
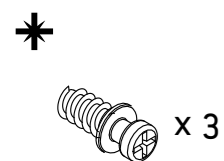
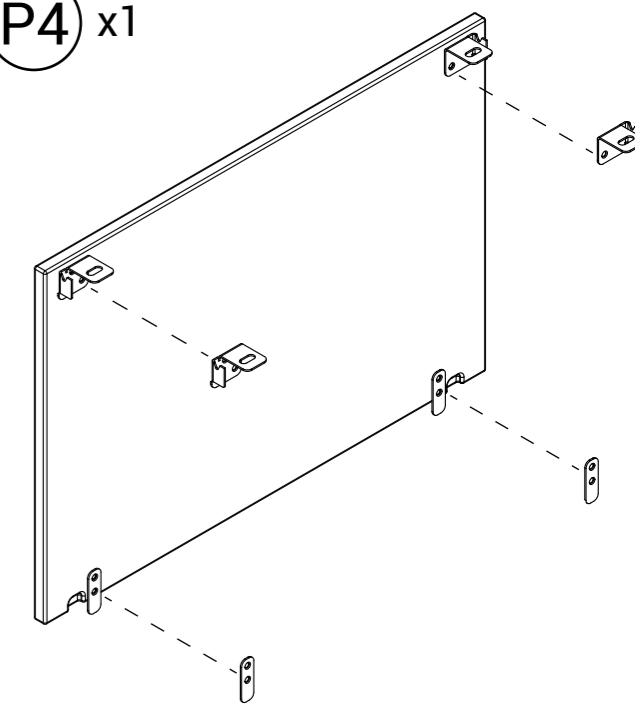

VÉRIFIER LA
POSITION
DES JOINTS
AMORTISSEURS

*

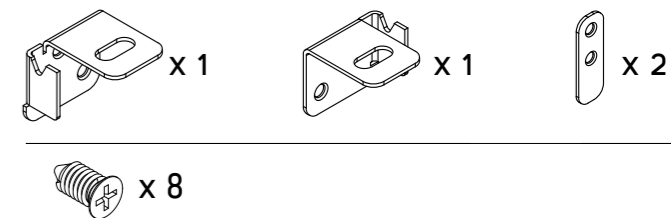
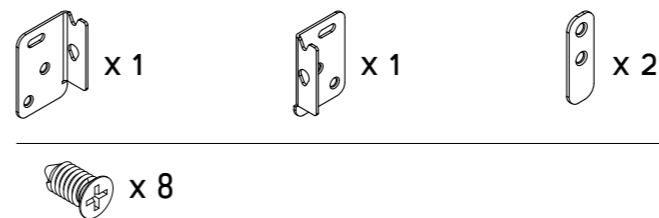
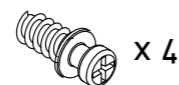

T3 102

T4 136



pozi 6 pans SQ

VISSER LES FACADES
SUR LE CHÂSSIS PUIS
EMBOITER LES COTES

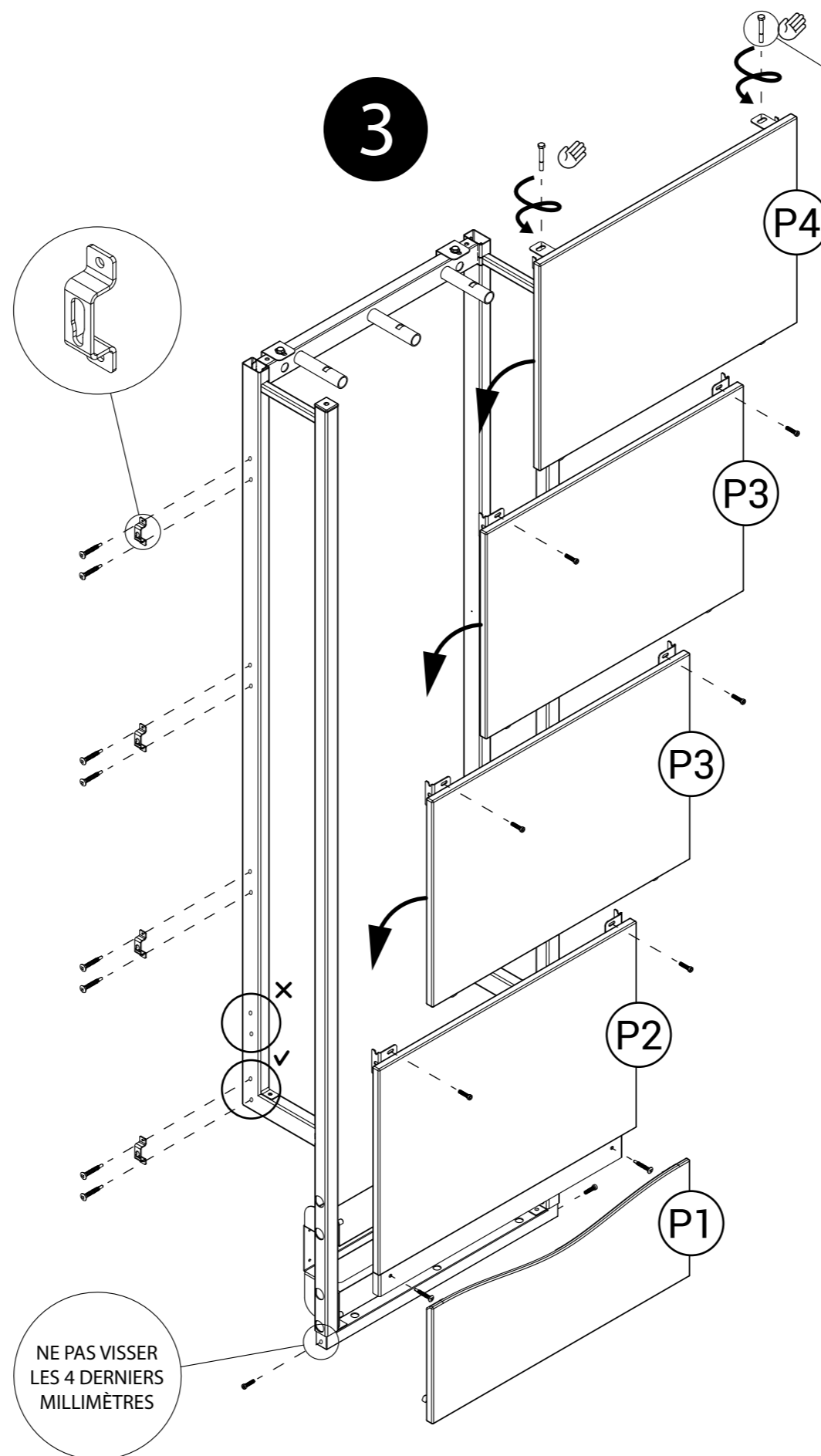
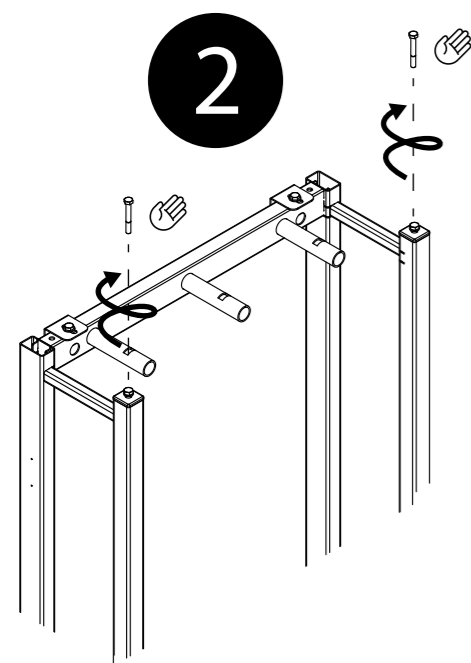

NE PAS VISSER
LES 4 DERNIERS
MILLIMÈTRES

POUR UNE
INSTALLATION
ENCASTRÉE
REPLACER LES VIS
PAR DES TIGES
FILETÉES

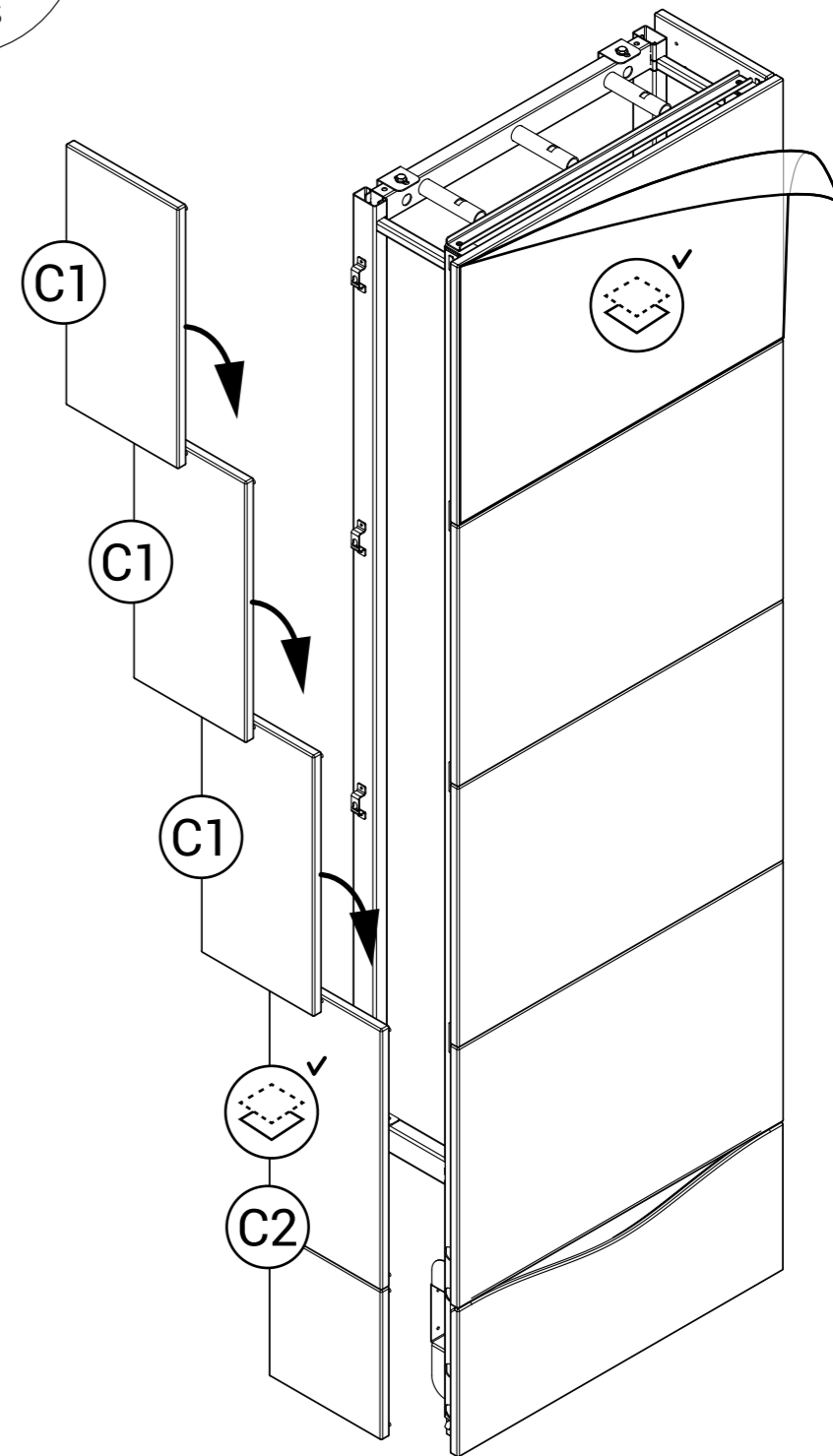

DÉVISER DES POTEAUX AVANT
LES 2 VIS M8 ET LEURS RONDELLES
LES METTRE DE CÔTÉS POUR L'ÉTAPE 2

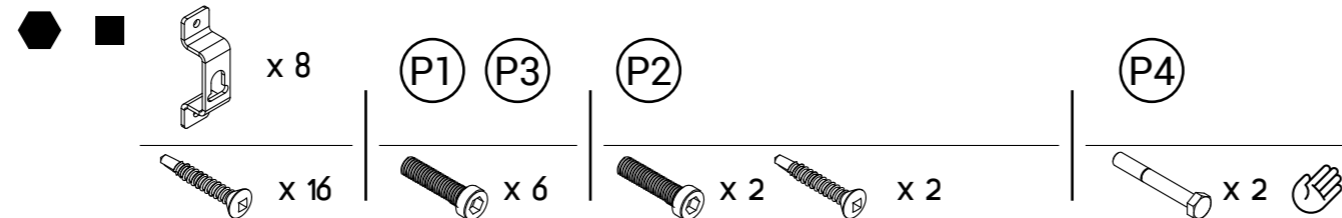
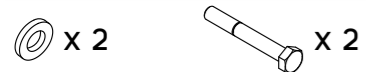

EMBOÏTER MANUELLEMENT
LES TÊTES DE VIS
DANS LES FERRURES

